

Dearborn, Michigan
NOISE-CON 2008
2008 July 28-30

Some Limitations of Ray-Tracing Software for Predicting Community Noise from Industrial Facilities

Frank H. Brittain¹
Bechtel, Corp
2255 Peavine Valley Road
Reno, NV 89523

Marlund E. Hale²
Advanced Engineering Acoustics
2663 Bristol Ave.
Simi Valley, CA 93065

ABSTRACT

Ray-tracing software has proven to be a valuable and powerful tool to predict community noise from industrial facilities. Accurate predictions are necessary to select the noise reductions needed to meet regulations and/or project noise limits, and then to determine individual equipment noise limits, select add-on noise controls, and confirm the plant will comply with its noise limits. Although ray-tracing and similar image-source software packages have proven to be powerful, they have many limitations. To use ray-tracing software effectively to model community or in-plant noise, the user needs to understand those limitations. How the software handles barriers is considered the most significant limitation. Further, ray tracing does not adequately predict levels when the wavelength of sound is comparable to dimensions of objects in the transmission path, when diffuse reflections occur, or when sound is scattered and transmitted by equipment and piping. The empirical methodology (ISO 9613-2) used to predict outdoor propagation, including ground effects, also imposes limitations. This paper identifies and discusses many of the more important limitations of ray-tracing software for predicting community noise. Examples are given. Commercially available software is identified, but no attempt is made to compare available packages.

1. Background - What Is Ray-Tracing Software?

Ray-based acoustical modeling assumes that sound acts like rays of light, which are used to find receivers and intervening objects and then predict or calculate the sound pressure level (SPL). SPLs can be predicted in the community or close to the source, at isolated receivers or as contours. Outdoor propagation from a point source is computed by summing multiple attenuations with distance, using some standard, usually ISO 9613, Part 2¹. Everything else, including tracing sound rays and defining finite-sized sources, is handled by the ray-tracing software. The accuracy of output predictions depends on how the user chooses to model the situation, and how the software treats the input data. Accurate predictions are needed to select the noise reductions needed to meet regulations and/or project noise limits; then to determine individual equipment noise limits and select add-on noise controls; and finally to confirm that the plant will comply with applicable noise limits.

¹ Email address: fhbritta@bechtel.com

² Email address: noisedoc@aol.com

The advantages of ray-tracing software include the ability to manage data of very large projects, screening by multiple barriers and finite-sized sources, and multiple reflections by screens and objects. Ray-tracing software allows the user to define line and area sources, which can be used to model buildings. Software breaks or partitions finite-sized sources into many point sources – automatically for ray-tracing software and typically from user-selected options for image source software. These advantages lead to more precise modeling of sources and propagation paths, and thus more accurate predictions. The price of this power is complexity, and a long and steep learning curve. Ray-tracing software is far more complex than it first appears to be. Effective use of this software requires significantly greater expertise than acoustical modeling using a spreadsheet. The following are some commercial ray (many reflections) and image source (usually one reflection) modeling software packages: CadnaA (DataKustik), IMMI (Wölfel), Mithra (01dB-Stell), SoundPLAN (Braunstein + Berndt GmbH), and SMP9613 (Power Acoustics, Inc.).

2. Assumptions and Omissions

There are a number of assumptions and omissions the authors have made because of space constraints. This paper cannot include every aspect of the limitations of ray-tracing software or the many outdoor sound propagation methodologies and standards. Only limitations of ISO 9613-2 are discussed. No other outdoor sound propagation standards or methodologies are referenced. The paper also does not cover atmospheric effects *per se*, but only where needed to explain a limitation.

The following terminology applies to this paper. When “9613” is used, it means ISO 9613, Part 2 or its equivalent, ISO 9613-2. “Ray-tracing software” refers to commercial software packages. “Ray tracing” means either 9613 and/or commercial ray-tracing software.

Because the paper’s topic is limitations, there is no attempt to describe 9613 or ray-tracing software, except to explain a limitation. Very limited guidance on how to use ray tracing is given. Input, output, database functions, and graphics are excluded. Topics discussed apply generally to ray-tracing packages and image software (e.g., SMP9613) used in outdoor community noise predictions. This paper is limited to the authors’ experience with ray-tracing software and its application, and is not intended to imply a complete knowledge of all available software. The authors make no attempt to compare differences or peculiarities of specific ray-tracing software packages. The inherent complexity and user learning curve have been discussed previously by the authors². Attenborough³ and Witte and Ouwerkerk⁴ provide helpful evaluations of 9613.

3. What Does Ray-Tracing Software Predict?

On one hand, the answer to this question seems obvious – it predicts or calculates the sound pressure level (SPL) in the community at isolated receivers or as contours. ISO 9613-2 is an empirically based engineering method, in which octave-band attenuations include both geometrical spreading and other attenuations. For each point source, the SPL is computed from the sound power level (PWL) as follows:

$$\text{SPL}|_d = \text{SPL at a distance } d \text{ from a point source} = \text{PWL} - \text{Attenuations} + \text{Directivity}. \quad (1)$$

The distance (d) from a source to a receiver can be one meter to at least a thousand meters. Directivity is input to the software by the user. Propagation over water⁵ is specifically excluded by 9613.

On the other hand, the answer is not obvious. According to 9613, various attenuations – one at a time in octave bands – are combined for a long-term average (say, one year) under downwind atmospheric conditions favorable to propagation of sound. Wilson⁶ indicates downwind propagation is equivalent to propagation in a moderate thermal inversion, both of which result in a downward refracting atmosphere. Yet these conditions are seldom constant. A long-term average would include many different atmospheric conditions and ground covers. Thus, a SPL calculated according to 9613 is not applicable to any one atmospheric condition or ground cover. Daigle and Stinson⁷ demonstrate that 9613 calculations are not applicable to propagation over newly fallen snow.

Geometrical divergence is calculated using spherical spreading (-6 dB/doubling of distance) from a point source, which corresponds to cylindrical spreading (-3 dB/doubling of distance) from a line source (or a line of closely spaced point sources). This implicitly assumes a neutral atmosphere. However, for propagation downwind or in a moderate inversion, the actual rate of divergence (in absence of atmospheric absorption) is often much less than nominal spherical or cylindrical divergence^{8,9}. Lower rates of actual divergence (attenuation) result in much higher noise levels than are predicted by ray-tracing software.

ISO 9613-2 implicitly assumes that wind blows from each source to each receiver, as shown in Figure 1. Although each receiver cannot be downwind simultaneously, this assumption is useful in designing a facility to meet a not-to-exceed community noise limit, as shown in Figure 1a. As suggested by Figures 1b and c, actual levels can be lower than predicted, because each receiver cannot be downwind of each source at the same time.

4. Modeling Accuracy

ISO 9613-2 method estimates the accuracy of the A-weighted SPL it predicts as ± 3 dB for distances up to 1 km. No estimated accuracy beyond 1 km is given. This estimate of accuracy is only for the long-term downwind average, and does not apply where there are reflections, screening, or other noted exclusions. The estimated accuracy excludes uncertainties in the PWL of sources. The accuracy for any octave band and tones is “somewhat” less than ± 3 dB, but no estimate of accuracy is given. However, 9613 and ray-tracing software are routinely used for distances beyond 1 km. Melding ray tracing with 9613 raises issues about the resulting predictions, because 9613 calculations do not apply to any one atmospheric condition; do not address wind speed and direction, or ground cover; and exclude propagation over water. In some software packages, the user can choose settings (such as search angle, number of reflections, and overall accuracy tolerance) that affect the resultant accuracy and compute speed. Further, accuracy depends on how a plant is modeled.

5. Barriers

Ray tracing has great advantages when calculating insertion loss (IL) of barriers, which can be buildings, tanks, large equipment, cooling towers, hilly terrain, and sound walls. Sometimes 9613 and ray-tracing software calculate erroneously high ILs, and lower than realistic SPLs. However, its treatment of barriers is also considered the most significant limitation of 9613.

The so-called “speed-bump” effect¹⁰ can be a problem. When strictly applied, 9613’s formulation gives a significant IL from a speed bump around a plant, which is obviously incorrect. This is caused by two effects: First, 9613 calculates a barrier IL even though in the real world wave length effects result in an IL of essentially zero (see Section 8); and second, the calculated diffraction of a straight ray (assumed by 9613 and used by ray-tracing software) when it passes over but close to a barrier (bright zone or negative path length difference). ISO 9613-2 gives a smooth transition between the bright and shadow zones. Older versions of ray-tracing software often calculated the speed-bump effect, but many now have included special features (sometimes with a numerical switch) to eliminate this effect.

ISO 9613-2 uses straight-ray barrier diffraction, and assumes each receiver is downwind of each source. Downwind (and in a moderate inversion) rays of sound tend to arc over the top of objects on the ground with reduced or no attenuation, as shown in Figure 2. Curved rays (downwind or in a moderate inversion) tend to produce actual ILs lower than predicted, and thus higher actual SPLs than predicted. For example, if a source, barrier, and receiver have the same height (grazing barrier incidence) and they are separated by 1 km from each other, 9613 calculates an IL of 4.8 dB, which is unrealistic. When a barrier is close to either the source or the receiver, 9613’s formulation works well. When the barrier is located at a larger distance from either, the predicted ILs are normally unrealistically high. Serious doubts arise in predicting the IL for a barrier not close to either. Brittain and Parzych¹¹ use curved rays (in a modification of SMP9613) to show the effects of distance from a residential barrier. They show the IL of A-weighted levels behind a 4-m high barrier protecting residences from a distant refinery unit can be up to 3 dB and 9 dB lower than predicted by 9613 at 30 m and 100 m from the barrier, respectively. Beyond 50 m, this residential barrier provides essentially no IL.

Only one top diffraction and two end diffractions are calculated. ISO 9613-2 can correctly compute all diffractions only of one barrier, whose top is a straight edge. A critical issue with multiple barriers is the number and location of diffraction paths around the ends of barriers. Adding barriers increases the number of possible paths around the ends of various combinations of barriers, none of which is handled by 9613. For long barriers and many multiple barriers, end diffractions are often negligible, so the limit of two end diffractions may not pose a problem. For tall multiple barriers, end diffractions can be the dominant transmission path as shown in Figure 3; ray tracing does not identify or calculate the dominant ray in Figure 3. Some ray-tracing software may have implemented provisions for end diffractions of multiple barriers similar to what is done for top diffractions, but it is doubtful that more than the two end diffractions are calculated. Diffraction by an end and then the top of another barrier is also not calculated by 9613, which is a limitation.

Figure 4 gives examples of two “pathological” barrier configurations that are not handled correctly by either 9613 or ray-tracing software. In each example (and by Figure 3), there are more than two end diffractions, but only two are calculated by 9613. Figure 4a shows two very different barrier heights, a vertical edge, and three source-receiver paths. Figure 4b has a high narrow barrier behind a long low barrier.

Parzych¹⁰ also points out deficiencies in 9613’s formulation of ground effects for a ray diffracted over the top of a barrier, and recommends a more accurate formulation. ISO 9613-2 sets the barrier IL to the greater of either the barrier attenuation or the ground attenuation. It appears that only SMP9613 software offers the option to use the more accurate formulation. Ground effects

for end diffractions are not included in 9613, and it is not known whether or how ray-tracing software handles ground effects for end diffractions.

6. Finite-Sized Source Effects

The size and shape of a large, finite-sized, or volume source affects both the actual and the predicted community noise level – beyond the obvious dependence of computed PWL on the size of the conformal surface.

A finite-sized or volume source in the shape of a box has a predicted and actual community noise level 4 dB lower than a point source at the same distance – when each source has the same octave-band PWL^{12,2}. In general, ray tracing correctly and automatically calculates noise radiated by large finite-sized sources. Users of ray-tracing software sometimes assume that contributions from a point source and a finite-sized source at a distant receiver should be identical, and erroneously apply a correction to make them equal. This can be readily demonstrated using any ray-tracing software. For example, each of five faces of the large source in the shape of a cube sitting on the ground, as shown in Figure 5, has directivity. The front surface (facing the receiver) has a directivity of 0 dB; the two side surfaces and top have a directivity of -5 dB; and the rear surface has a directivity of -20 dB^{13,14}. If both the point and volume source has a PWL of 100 dBA, the PWL of each identical face of the cube would be 93 dBA. Assuming reflections from hard ground, no atmospheric absorption, and the distance from each face of the volume and the point source essentially the same, the point source yields a predicted level of 61 dBA at the receiver, while the level from the cube is predicted to be 57 dBA. This difference in A-weighted SPL at a distant receiver is a limitation, which can unnecessarily increase costs of noise control.

When the SPL of a very large uniformly radiating volume source is predicted at 1 m from the center of a face (in the absence of contaminating sources), the SPL will be about 3 dB higher than the SPL used by ray-tracing to compute the PWL^{2,15}. This is caused by pressure fluctuations¹⁶ where particle velocities are parallel to the surface. The effect decreases exponentially with distance from the surface, and does not propagate to the far field. This is sometimes called the evanescent field. As the source size decreases, the magnitude of this effect decreases, and it disappears (as expected) for a point source. A correction can be computed to account for the source size effect. This limitation results in over predicting SPL.

Noise radiated by a finite-sized source can be strongly limited by radiation efficiency when the source dimensions approach or are lower than the wavelength of sound. For example, a pipeline radiates little noise at lower frequencies, because of decreased radiation efficiency – even when there is considerable low frequency energy. Ray-tracing software calculates noise radiated by finite-sized sources independent of source dimensions, and dependent only on the PWL. Thus, a 1-m and a 20-m cube radiate the same acoustic energy if the PWLs are identical. However, when PWL is measured/computed on a hemisphere, the measurements automatically include any and all effects of radiation efficiency. Thus, predicted levels are accurate, because measurement/calculation of PWL makes up for deficiencies in ray tracing – as long as the measured and predicted sources are roughly the same shape and size and directivity is neglected.

7. Specular And Diffuse Reflections

Both ray tracing and 9613 include reflections from building walls, large equipment, barriers and other flat surfaces. This works well and reflections will be specular as long as the surface is

smooth and both of its dimensions are large compared to the wavelength of sound in the octave band of interest. The limiting octave band can be calculated using 9613, and is calculated by ray-tracing software. For the octave band whose center wavelength is just below the limiting octave band, the reflection is taken by 9613 as zero, which results in a step function in reflected sound between two octave bands. In reality, there will be appreciable reflected sound in some lower octave bands, and no step function in reflected sound for the frequency. For close-to-grazing incidence (of a ray of sound incident on the reflecting surface), the reflected energy calculated by 9613 becomes negligible. Again, there may be appreciable reflection of sound at grazing incidence, contributing to an actual SPL higher than is predicted.

Irregularities on the reflecting surface and clutter near the surface, including piping, structure, equipment, stairwells, etc., substantially affect reflections by scattering sound and causing diffuse reflections. A diffuse reflection can be viewed as a reflection at each point on the surface radiates in all directions, rather than in one direction for specular reflections. Irregular surfaces and clutter near a surface cause wavelength-dependent scattering of incident energy, and transform much of it into diffuse reflections. The balance between diffuse and specular reflections is difficult to predict or measure. As diffuse reflections increase, less energy is reflected specularly. Some incident sound energy is absorbed, which is an option in ray-tracing software. The importance of diffuse reflections is illustrated by the need to include both diffuse and specular reflections when predicting indoor propagation – even when the walls are nominally smooth¹⁷. Complex-shaped equipment also generates diffuse reflections. The inability of ray tracing to calculate scattering and diffuse reflections is a limitation. As an example of diffuse reflections, the walls of an HRSG (heat recovery steam generator, which extracts waste energy from a combustion turbine exhaust), are heavily cluttered as shown in Figure 6. The “thickness” of this surface clutter affects low-frequency reflections (say, below roughly one quarter of the wavelength of the octave band of interest).

As the dimensions of an object decreases compared to the wavelength, the amount of scattering increases. This is illustrated by the frequency response of a microphone and preamp. As the diameter decreases, the scattering is shifted to higher frequencies. The extent of scattering and diffuse reflections affects the predicted noise level, and is wavelength dependent. The inability of ray tracing to calculate wavelength-dependent phenomena is a limitation of ray-tracing.

8. Other Wavelength Effects and Difficult Geometries

Much of acoustics involves wavelength effects. Wavelength effects depend on wavelengths of sound, which are often temperature dependent, and not on frequency, which is not temperature dependent. For example, a fan has a constant frequency blade tone, but a tuned silencer must be designed to attenuate the temperature-dependent wavelength of the blade tone.

Ray-tracing software calculates levels using the empirical formulations of 9613, which includes wavelength effects to a very limited extent, except the empirical formulations for barrier IL and ground effects. Figure 7 shows five configurations where wavelength effects are likely to have a major effect in predicted community noise levels. First, an important wavelength-dependent limitation arises when the distance between a source and any reflecting surface, or any gap or opening on a transmission path, is small compared to the wavelength of sound in the octave band of interest. All configurations in Figure 7 have narrow gaps, slots or passages where wavelength dependent phenomena can be dominant, and wavelength-dependent software is needed to accurately predict. Further, when the equipment in Figures 7a to c have irregular surfaces (as

usually happens), diffuse reflections also occur. Figures 7d and e have a narrow slit or gap, which 9613 will calculate by excluding all wavelength effects. Ray tracing will compute each of these configurations, but frequency-dependent accuracy is adversely affected in an unknown way. Second, diffraction of a short barrier will exhibit wavelength effects. If the barrier is short compared to the wavelength in the octave band of interest, it will have reduced diffraction and IL. As the wavelength increases (low frequencies), this effect also increases.

A related limitation arises with multiple reflecting surfaces. Ray-tracing software cannot model many configurations with multiple reflecting surfaces moderately close to a source or on a transmission path(s), because 9613 only has provisions to model vertical, reflecting surfaces (barriers or building walls). There are no provisions in 9613 for horizontal or oblique reflecting surfaces. Because applicable configurations cannot be adequately defined, examples are given in Figures 7a to c, which have multiple reflecting surfaces that are not vertical. Some ray-tracing software packages include a special (not from 9613) provision for modeling horizontal and/or oblique reflecting surfaces (3D reflectors in CadnaA and floating horizontal barriers in SoundPLAN), but these appear to have no or at most one reflection. Ray-tracing software cannot model the multiple reflecting surfaces of Figure 7a to c.

9. Ground Effects and Ground Reflections

Sound levels at the receiver, which include ground effects, can vary widely, over a few minutes or many months, due to atmospheric effects, particularly wind speed and direction. There are other limitations in 9613 the user needs to consider. Ground effects arise from interactions between the direct path (straight ray between source and receiver through the air) and the reflected path (straight ray between source and receiver reflected by the ground). Frequency-dependent ground effects in 9613 are complicated and use empirical formulations to approximate a long-term average attenuation from ground effects. ISO 9613-2 calculates ground effects using three regions between the source and the receiver, i.e., source, receiver, and middle region. The ground factor G is zero for a hard surface, and 1 for a soft or porous surface. The user must choose the ground factor for each region. In modeling ground that falls away sharply from the source, Ray¹⁸ suggests setting $G = 0$ to account for a ground plane that has no reflections.

Large source-receiver distance and low or high source heights raise questions about accuracy of ground attenuation in 9613. Both the size of the source region (30 times the source height) and the attenuation in it are questionable. For example, for a 100-m-high stack, a source region of 3,000 m is nonsense, particularly for receivers close to the source. Very low height sources are also problematic, and the source region goes to zero for a point source resting on the ground. Ray¹⁸ indicates a minimum source height of 1.5 m should be used. When the source height is less than 1.5 m over soft ground, the attenuation predicted using $G = 1$ is unreasonably high. As a work around, Ray¹⁸ suggests using hard ground in cases where the source height is less than 1.5 m.

Ground effects in 9613-2 implicitly assume a low angle of incidence of the reflected ray to the ground. For larger angles of incidence (say, beyond 15 degrees), 9613 is silent, and ray-tracing software uses ground effects for such reflections, which introduce inaccuracies of unknown magnitude in predicted noise levels at receiver locations.

10. Transmission And Reflections From Pipe Racks And Equipment

Most process, power, and LNG (liquefied natural gas) plants have complex banks of rotating equipment, piping, pipe racks, air coolers, vessels, and tanks, which are usually densely packed as shown in Figure 8. The density often effectively blocks the line of sight, and heights often reach 10 to 50 m.

Depending on the location relative to sources and a receiver, pipe racks, piping, and banks of densely packed equipment dramatically affect propagation. Incident sound is heavily scattered, reflected diffusely, and transmitted. Further, equipment and piping are often sufficiently dense that the tops and edges of pipe racks and banks of equipment diffract sound, and act like porous barriers. Transmitted sound and diffuse reflections are wavelength dependent. The longer the path through the equipment and piping, the greater these effects. Modeling a pipe rack as a barrier usually gives erroneous results, because a barrier has only specular reflections and no transmission. Reflection or backscattering causes sound to be propagated in the opposite direction. Even when not densely packed, equipment and piping significantly affect sound propagation. Banks of equipment and piping often affect ground effects. No specular reflection or transmission is calculated by ray-tracing software, and 9613 has no empirical provisions for scattering by densely packed equipment and piping.

Little information is available to quantify reflection, transmission, and diffraction (sometimes called screening) by densely packed equipment and piping. Middleton and Seebold¹⁹ give combined attenuations of pipe racks and equipment measured in a refinery, which was not operating. Relocatable noise sources were used. EEMUA²⁰ gives two plots of wavelength dependent screening (minimal and significant) by refinery equipment.

11. Conclusions

There is an apparent dichotomy. This paper identifies many important limitations of ray tracing. On the other hand, ray tracing has been used successfully to design facilities for many years. Until prediction technology, including Nord2000²¹ for outdoor propagation, that significantly reduces these limitations becomes commercially available and feasible for large projects, there is no choice but to continue to use ray tracing. Spreadsheets and software that do not compute reflections have even greater limitations. However, ray-tracing software needs to be used with great discretion. By understanding its limitations, ray tracing can be used much more effectively. After identifying limitations that have a major effect on predicted levels at the controlling receiver, case-by-case evaluations and accommodations can be made. Without an awareness or understanding of the prediction method's limitations, the noise control engineer will obtain predicted levels, but is not likely to have the ability to evaluate their accuracy and significance. Except for errors in noise source data, the largest limitations in predictions of a long-term average downwind community noise level come from how the software handles barriers, multiple reflecting surfaces, pipe racks and banks of equipment, ground effects, and diffuse reflections. Further, most community noise from a plant usually comes from a handful of dominant sources. Knowing the expected dominant sources and the most significant limitations, the noise control engineer has a place to start evaluating the impact of limitations of ray tracing predictions on noise control, including costs and project decisions. Since the cost of reducing one dB from a predicted community noise level can significantly exceed \$ one million, limitations of 9613 and ray-tracing software can greatly affect cost. Now – gentlemen and lady, it's time to start your engines.

REFERENCES

- ¹ ISO 9613-2, "Acoustics — Attenuation of sound during propagation outdoors — Part 2: General methods of calculation," International Standards Organization, Genève, Switzerland, 1996.
- ² Frank H. Brittain and Marlund E. Hale, "Issues in using ray-tracing software for predicting community noise from power plants," Special Session on power plant noise, *Proc. NOISE-CON 2003*, Cleveland, OH (Noise Control Foundation, Poughkeepsie, New York, 2003).
- ³ Keith Attenborough, "Aspects of the new ISO standard for outdoor noise prediction," *Acoustic Bulletin*, UK, (January/February 1996).
- ⁴ R. Witte and M. Ouwerkerk, "Comments on ISO 9613-2," *INTER-NOISE 96*, Liverpool, (1996).
- ⁵ Frank Brittain and Xiao Di, "Effect of parameters on modeling low-frequency propagation of petrochemical plant noise over water," *J. Acoust. Soc. Am.* **120**, 3336 (2006).
- ⁶ Keith Wilson, "Atmospheric effects in ISO 9613-2," Special Session on ISO 9613-2, *Proc. NOISE-CON 2004*, Baltimore, MD (Noise Control Foundation, Poughkeepsie, New York, 2004).
- ⁷ Giles A. Daigle and Michael R. Stinson, "Attenuation of environmental noise: Comparing predictions of ISO 9613-2 and theoretical models," Proceedings of Inter-Noise 2005, Rio de Janeiro (7-10 August 2005).
- ⁸ James P. Chambers, Hugh Saurenman, Robert Bronsdon, Louis Sutherland, Ken E. Gilbert, Roger Waxler, Carrick Talmadge, "Effects of temperature induced inversion conditions on suburban highway noise levels," *Acta Acustica united with Acustica* 92 pp. 1060-1070 (2006).
- ⁹ Frank Brittain and Xiao Di, "Effect of parameters on modeling low-frequency propagation of petrochemical plant noise over water," *J. Acoust. Soc. Am.* 120, 3336 (2006).
- ¹⁰ David Parzych, "Handling of barriers in ISO 9613-2," Special Session on ISO 9613-2, Proceedings of Noise-Con 2004, Baltimore, MD, (12- 14 July 2004).
- ¹¹ Frank Brittain and David J. Parzych, "Modeling the reduced insertion loss of a sound barrier in a downward refracting atmosphere for a petrochemical plant," Proceedings of Inter-Noise 2006, Honolulu, HI (3-6 December 2006).
- ¹² Frank Brittain, "Issues in predicting community noise for power plants", Special Session On power plant noise, *Proc. NOISE-CON 1997*, State College, PA (Noise Control Foundation, Poughkeepsie, New York, 1997).
- ¹³ Leo L. Beranek and István L. Vér, "Outdoor sound propagation," Chap. 5 in *Noise and Vibration Control Engineering-Principles and Applications*, edited by Leo L. Beranek and Istvan L. Ver (Wiley, New York, 1992).
- ¹⁴ *Outdoor Propagation*, VDI 2714 (Verein Deutscher Ingenieure), Düsseldorf, (1988). (in German).
- ¹⁵ D.A. Bies and C.H. Hansen, *Engineering Noise Control Theory and Practice*, Third Edition, pp. 266 (E & FN Spon, London & New York, 1996).
- ¹⁶ *Ibid.*, pp. 249.
- ¹⁷ Hodges, Murray, Personal Communication (2002).
- ¹⁸ Elden Ray, "Applications of attenuations and reflections in ISO 9613-2, Acoustics – Attenuation of Sound During Propagation Outdoors – Part 2: General Method of Calculation," Special Session on ISO 9613-2, *Proc. NOISE-CON 2004*, Baltimore, MD (Noise Control Foundation, Poughkeepsie, New York, 2004).
- ¹⁹ A. H. Middleton and J. G. Seebold, "Propagation of machine generated sound within and around a process plant," Proceedings of Inter-Noise 1972, Washington D.C., (4-6 October 1972).
- ²⁰ Engineer Equipment and Materials Users Association (EEMUA), Noise Procedure Specification, London, Publication 140 (1988).
- ²¹ Jørgen Kraugh, Svein Storeheier and Hans Jonasson, *Nordic Noise Prediction Method, Nord2000, Summary Report: General Nordic Sound Propagation Model and Applications in Source-Related Prediction Methods*, Delta Acoustics for Nordic Noise Group, Report AV 1717/01 (December 2001, revised June 2002).

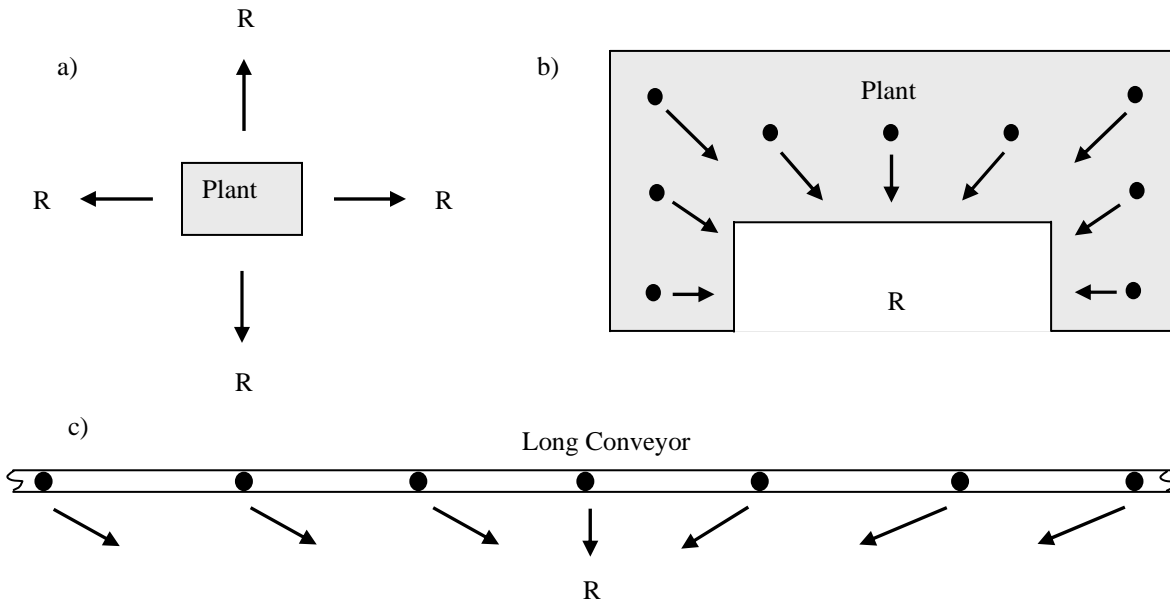

Figure 1: Three examples of ISO 9613-2's implicit assumption that wind blows from each source to each receiver. None of these cases are physically possible. (a) Industrial plant where the downwind assumption makes sense for design. (b) Industrial plant where predicted long-term average levels can be unrealistically high. (c) Long conveyor plant where predicted long-term average levels can be unrealistically high.

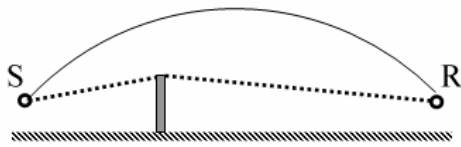

Figure 2: Long distance downwind arcing sound ray and diffracting 9613 straight ray.

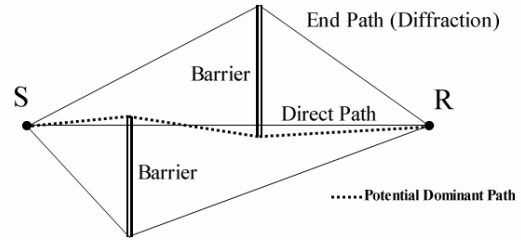

Figure 3: Offset barriers' potentially dominant path with direct path and 9613 end paths

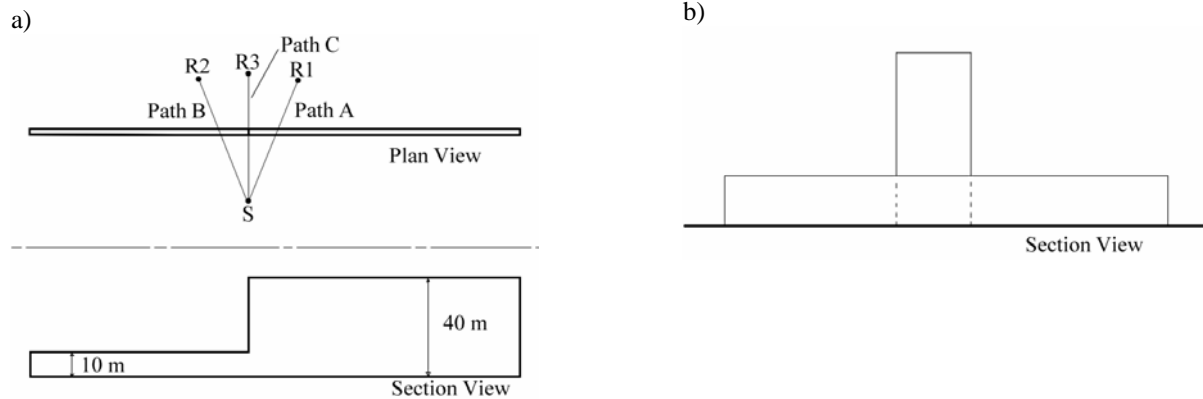

Figure 4: Sketches of pathological barrier examples which have more than two diffracting ends. (a) A barrier with a significant height change and three receivers with different source shielding. (b) A tall narrow barrier located a short distance behind a long lower barrier.

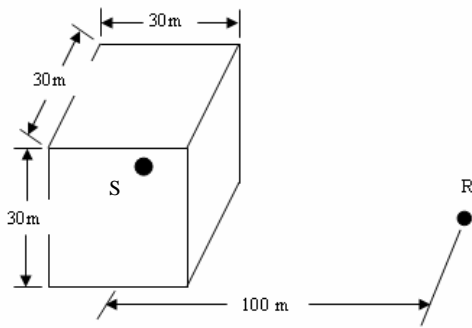

Figure 5: A cubic shaped finite-sized source that indicates how the boiler can be modeled as a point source or volume source. Due to directivity, the finite-sized source contributes about 4 dB less to A-weighted level at the receiver than the point.



Figure 6: Heat recovery steam generator showing surface clutter in the form of structure, piping, and platforms that scatter and diffusely reflect much of the incident acoustic energy.

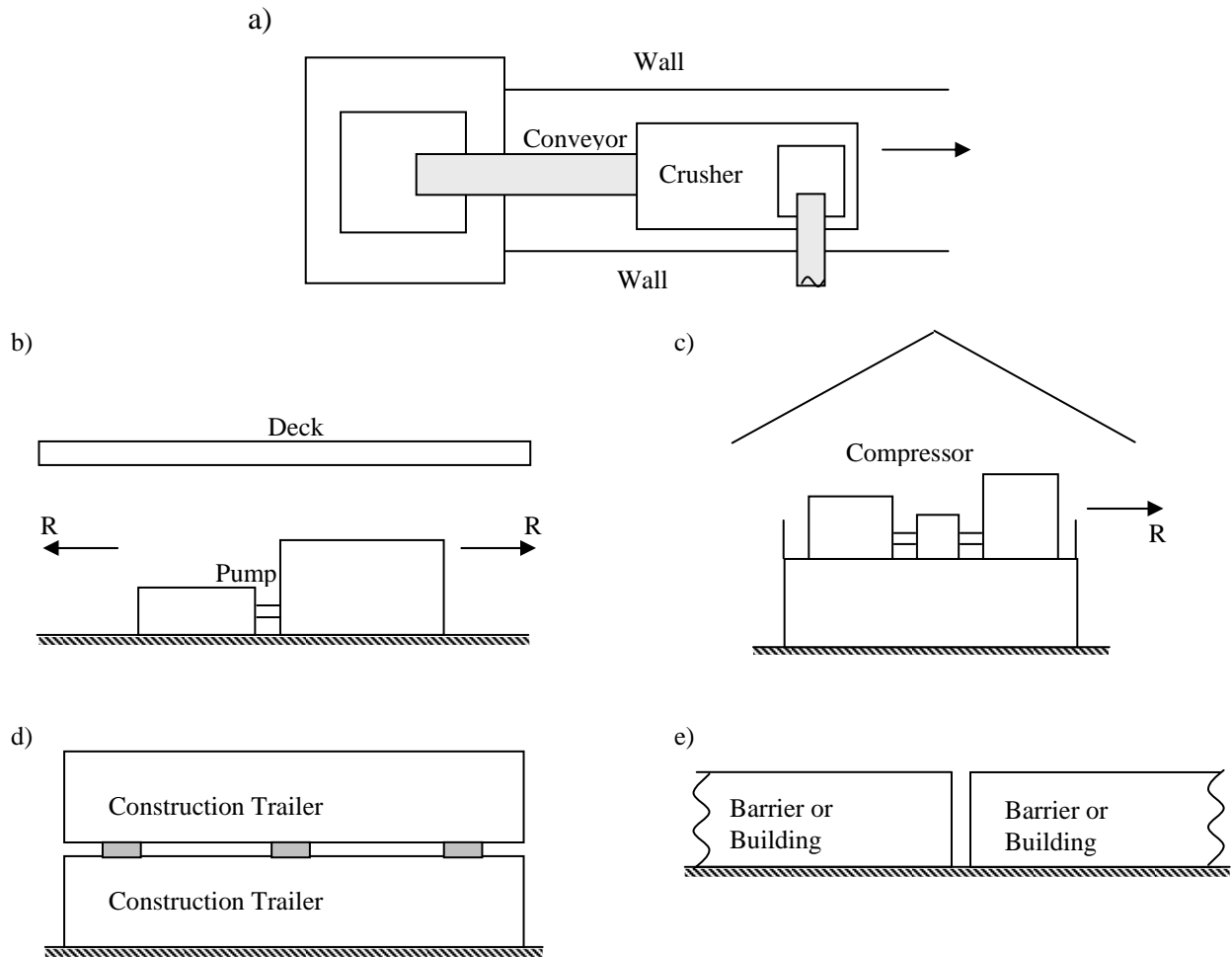

Figure 7: Configurations where wavelength effects at lower frequencies cannot be accurately computed by ray tracing (all), or ray-tracing software cannot model, because ray-tracing software do not support non-vertical surfaces need (b and c). (a) Conveyor and hoppers with vertical concrete walls. (b) Pump with concrete deck above. (c) Compressor shed with roofs and partial walls. (d) Stacked construction trailers with narrow slit. (e) Two building or barriers with a narrow slit.



Figure 8: Very large pipe rack with air coolers on the top that scatters, diffusely reflects, transmits, and diffracts incident sound.